

# Auger Compactor

## type SP / SPN

### Simply powerful

PRESTO auger compactors can be used wherever large quantities or even highly expansive, bulky recyclable and waste materials need to be disposed of in a small space. The screw shaft compacts the material into the coupled container by continuous rotary movements. The compacting unit remains firmly in place and the container is removed for emptying.

The PRESTO auger compactor as your functional, cost-reducing link in the recycling cycle. We design the optimum solution for your disposal requirements..

### Individually usable

for materials and recyclables like paper and cardboard, packaging and commercial waste, insulation materials through to foil.

for industries such as retail and industrial companies, logistics centers, wholesalers, retail chains and discounters as well as the paper and packaging industry and many more



### Versatile & efficient

- For continuous feeding with a high degree of compaction
- Insensitive to dirt with low maintenance requirements
- Quiet and flexible for a wide range of applications
- Material-specific feeding equipment and accessories for optimal compaction
- Self-sufficient compaction unit or integration into work and production processes
- Space-saving installation

### Economical & elegant

- Filling weights of the container up to 50% higher compared to hydraulic compactors
- Low-noise operation of < 65 dB (A)
- RAL color selection from a variety of lead and chromium free paints
- Many years of experience in construction, design and project planning
- PRES-TO-GO control > reduced power consumption, CO<sub>2</sub> reduction through optimal route planning
- Overview, access and management via PRES-TO-web / PRES-TO-GO app

SP

SPN

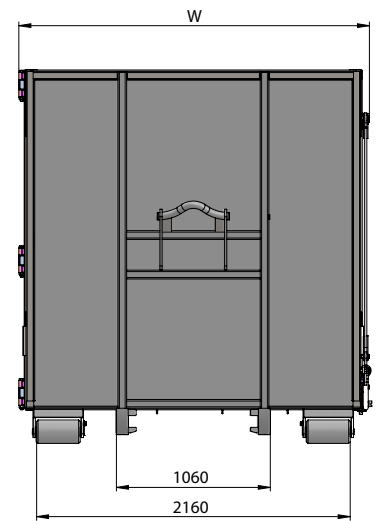
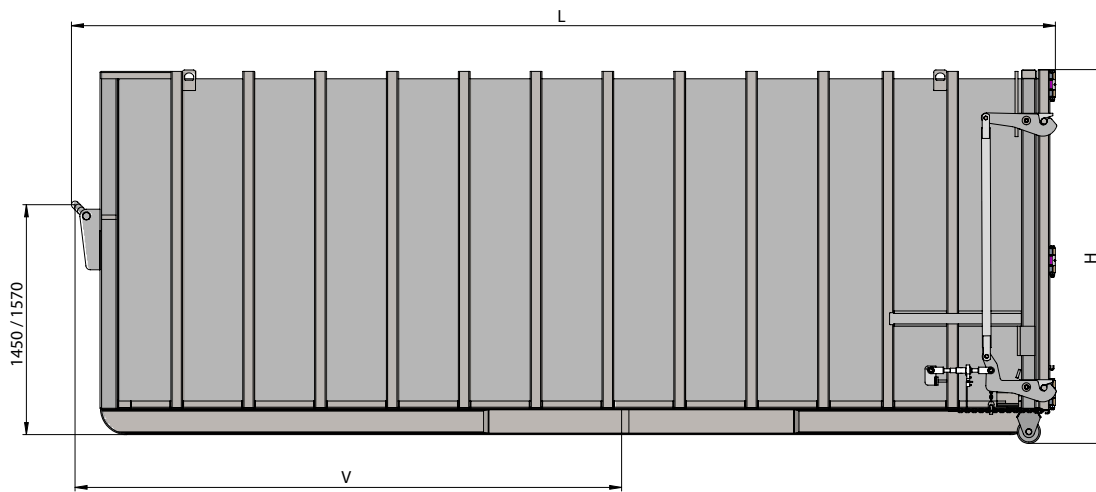
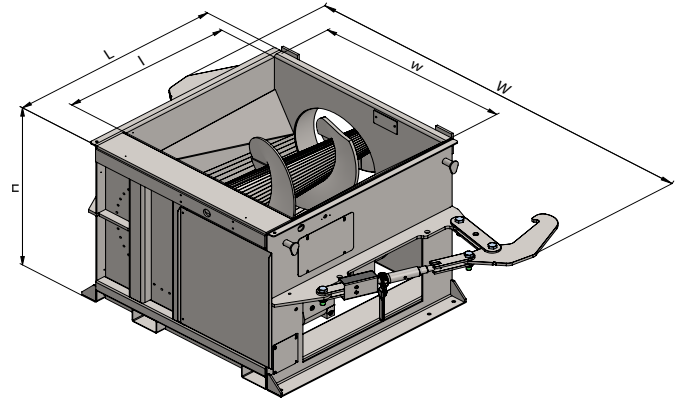
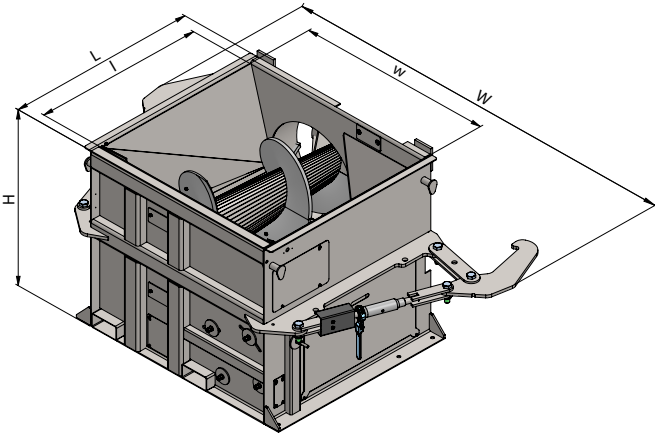

Machine		SP	SPN 11	SPN 15
Length (L)	mm	1335	1510	1510
Width (W)	mm	2830	2830	2830
Height (H)	mm	1250	1250	1250
Filling opening (l x w)	mm	1200 x 1380	1225 x 1380	1225 x 1380
Auger speed	n/min	14	15	15
Auger diameter	mm	800 / 500	800 / 500	800 / 500
Pressing force	kN	7,5	6,83	9,55
Specific pressing force	kN/m <sup>2</sup>	38,3	43	60
Machine weight	kg	1800	2200	2200
Motor power rating	kW	11	11	15
Electrical power supply	3 L / N / PE; 400 V, 50 Hz			

Container		SPB-U 25	SPB-U 28	SPB-U 30	SPB-U 32	SPB-U 25V	SPB-U 28V	SPB-U 30V	SPB-U 32V
Volume	m <sup>3</sup>	25	28	30	32	25	28	30	32
Length (L)	mm	5690	6240	6780	7205	5770	6320	6860	7285
Width (W)	mm	2420	2420	2420	2420	2420	2420	2420	2420
Height (H)	mm	2500	2500	2500	2500	2500	2500	2500	2500
Locking dimension (V)	mm	3265	3515	3765	4015	3265	3515	3765	4015
Container weight	kg	2820	3050	3250	3410	3110	3300	3540	3700

Subject to technical changes; the figures are rounded and may vary depending on the equipment version.

\* Coupling device dimensioned for centre installation; V-reinforced version; container in round version on request.

05/2024

more data-  
scan hier

**PRESTO GmbH & Co. KG**

Gewerbepark 4 | D-49196 Bad Laer  
Fon +49 5424 2927-0 | Fax +49 5424 2927-90  
kontakt@presto.eu | www.presto.eu

